

Product Specification

Specification

PerkinElmer Optoelectronics GmbH
Wenzel-Jaksch-Straße 31
65199 Wiesbaden, Germany
Phone: +49 (6 11) 4 92-0
Fax: +49 (6 11) 4 92-1 77
<http://www.perkinelmer.com>

Product Picture:

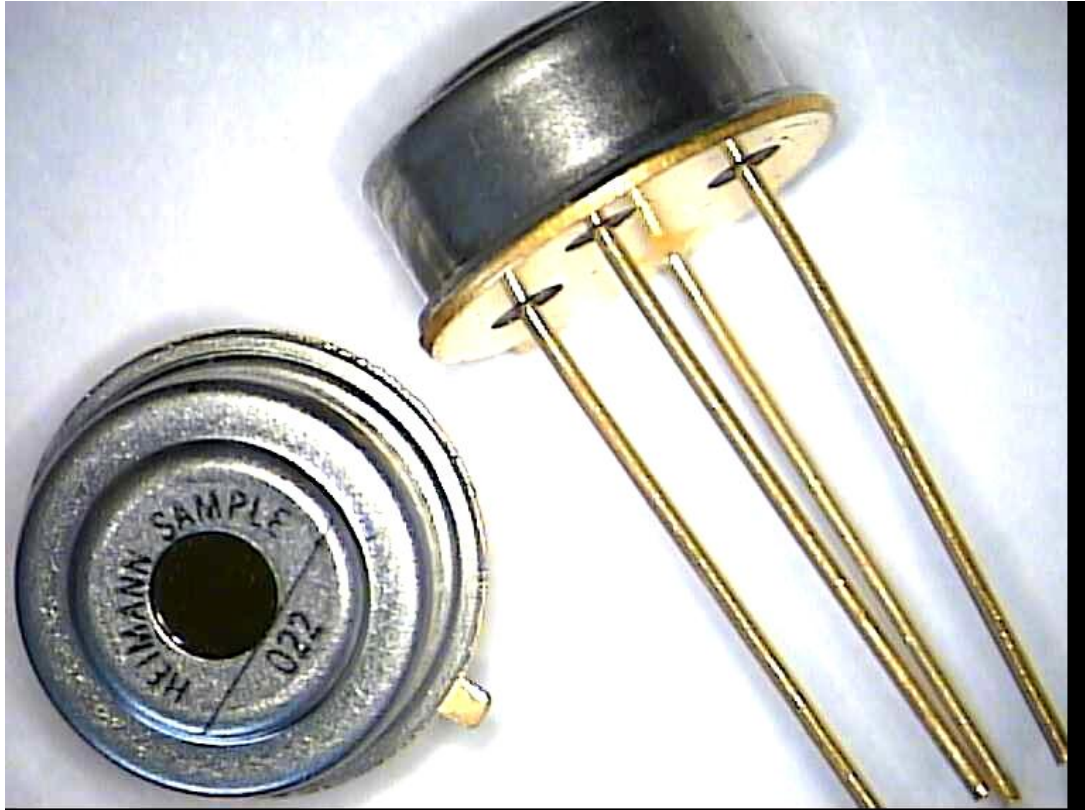

Product Name: TPS334	Device Type: Thermopile Sensor	Part Number: 96383161
--------------------------------	--	---------------------------------

Rev. No.	Date	Pages	Revision Record	Drawn	Checked
00	12DEC2001	10	Initial Release	MS	

Customer:	Reference No.:	First Used:
Released		Date

TABLE OF CONTENTS

1	SCOPE	3
2	GENERAL CHARACTERISTICS	3
2.1	ABSOLUTE MAXIMUM RATINGS	3
2.2	ELECTRICAL PARAMETER	3
2.2.1	<i>Thermopile</i>	3
2.2.2	<i>Temperature Reference</i>	4
2.3	HANDLING REQUIREMENTS	4
3	TYPE CHARACTERISTICS	4
3.1	DESIGN CHARACTERISTICS	4
3.2	ELECTRICAL CHARACTERISTICS	5
3.2.1	<i>Thermopile</i>	5
3.2.2	<i>Thermistor</i>	5
3.3	OPTICAL CHARACTERISTICS	6
3.3.1	<i>Parameter</i>	6
3.3.2	<i>Sample Curve</i>	6
3.4	FILTER CHARACTERISTICS	7
3.4.1	<i>Parameters</i>	7
3.4.2	<i>Sample Curve</i>	7
3.5	MECHANICAL DRAWING	8
4	QUALITY	8
4.1	QUALITY SYSTEM	9
4.2	LOT ACCEPTANCE TEST	9
4.2.1	<i>Test Conditions</i>	9
4.2.2	<i>Test Parameter</i>	9
4.2.3	<i>Test Level at the End Test</i>	9
4.2.4	<i>Test Level at the Quality Test</i>	10
4.3	REFERENCED DOCUMENTS	10
4.4	LIABILITY POLICY	10

1 SCOPE

The HEIMANN thermopile sensor consists of a series of thermoelements, forming a sensitive area covered by an IR-absorbing material. The sensor is hermetically sealed into a metal housing. The size of the housing is similar to a TO-package with a window opening. The window is equipped with an IR-transmissible filter. An additional temperature reference sensor can be installed in the sensor housing. The thermopile sensor exhibits an almost white noise, comparable to an ohmic resistance. The thermopile output signal is direct proportional to incident radiation power largely independent from the wavelength. The frequency behaviour corresponds to a low pass characteristic.

2 GENERAL CHARACTERISTICS

2.1 ABSOLUTE MAXIMUM RATINGS

Parameter	Symbol	Limits			Units	Conditions
		Min	Typ	Max		
Ambient Temperature Range		-40		100	°C	Operation / Storage

2.2 ELECTRICAL PARAMETER

2.2.1 Thermopile

Parameter	Symb	Limits			Units	Conditions
		Min	Typ	Max		
Sensitive Area			0.7*0.7		mm ²	Absorber
Resistance	R _{TP}	50	75	100	kΩ	
Responsivity	S _V		55		V/W	-,500K,1Hz ¹⁾
Time Constant ²⁾	τ		25		ms	
Noise Voltage	V _{RMS}		35		nV/√Hz	R.M.S.,25°C
Noise Equivalent Power	NEP		0.64		nW/√Hz	-,500K,1Hz ¹⁾
Detectivity	D*		1.1*10 ⁸		cm√Hz/W	-,500K,1Hz ¹⁾
TC of Resistance		0	0.02	0.05	%/K	Temperature Coefficient
TC of Responsivity		-0.01	0.02	0.05	%/K	

Note 1: The values are defined without filter.

Note 2: The time constant can be measured as response to an object temperature jump (low to high or high to low) based on the following equations :

$$\text{Low to High : } \Delta V = \Delta V_{\max} * \left(1 - e^{-\frac{t}{\tau}} \right) \Rightarrow \Delta V = \Delta V_{\max} * \left(1 - \frac{1}{e} \right)$$

$$\text{High to Low : } \Delta V = \Delta V_{\max} * \left(e^{-\frac{t}{\tau}} \right)_{t=\tau} \Rightarrow \Delta V = \Delta V_{\max} * \left(\frac{1}{e} \right)$$

2.2.2 Temperature Reference

<i>Typ</i>						
Thermistor 100kW						
<i>Parameter</i>	<i>Symbol</i>	<i>Limits</i>			<i>Units</i>	<i>Conditions</i>
		<i>Min</i>	<i>Typ</i>	<i>Max</i>		
Resistance	R _{TH}	28.5	30	30.9	kΩ	At 25°C
BETA-Value	β	3944	3964	3984	K	Defined at 25°C/100°C

2.3 HANDLING REQUIREMENTS

Stresses above the absolute maximum ratings may cause damages to the device.

The sensor can be damaged by electrostatic discharges. Please take appropriate precautions for the handling. The thermopile sensors can be damaged by electrostatic discharges. Please take appropriate precautions for the handling.

Do not expose the sensor to aggressive detergents such as freon, trichlorethylen, etc. Windows may be cleaned with alcohol and cotton swab.

Hand soldering and wave soldering may be applied by a maximum temperature of 300°C for a dwell time less than 10s. Avoid heat exposure to the top and the window of the detector. Reflow soldering is not recommended.

3 TYPE CHARACTERISTICS

3.1 DESIGN CHARACTERISTICS

<i>Parameter</i>	<i>Description</i>	<i>Material</i>
Case	TO5	
Cap	Round opening Ø2.5mm	Alloy Nickel
Header	TO39	Steel with gold plating over Ni coating
Leads	(3 isolated +1 ground) pins	Alloy with gold plating over Ni coating
Filter	STANDARD coating	Silicon base with diff. coating layers
Temperature Reference	Thermistor 30kΩ	Ceramic with gold terminations
Case Filling	The sensor is hermetically sealed to withstand a gross leaktest according to MIL Std.883 method 1014c1.	Dry nitrogen
Device Marking On Top Side	Manufacturer symbol + last 4 digits of the product number + 3 digits date code yww	

3.2 ELECTRICAL CHARACTERISTICS

3.2.1 Thermopile

Parameter	Symb	Limits			Units	Conditions
		Min	Typ	Max		
Resistance	R _{TP}	50	75	100	kΩ	25°C
Sensitivity	S _V	20	35	50	V/W	Standard filter, 500K, 1Hz, 25°C
Time Constant	τ		25	70	ms	25°C
Noise Voltage	V _{RMS}			40	nV _{RMS} /√Hz	

3.2.2 Thermistor

T	Rmin1	Rmin2	Rnom	Rmax2	Rmax1
°C	Ω	Ω	Ω	Ω	Ω
-40	844572	889932	907200	924468	951684
-35	618414	651564	663000	674436	694326
-30	457513	481993	489600	497207	511895
-25	341771	360026	365100	370174	381127
-20	257478	271207	274590	277973	286211
-15	195682	206099	208350	210601	216851
-10	149931	157900	159390	160880	165661
-5	115788	121934	122910	123886	127573
0	90086	94861	95490	96119	98984
5	70598	74335	74730	75125	77367
10	55708	58653	58890	59127	60894
15	44243	46578	46710	46842	48243
20	35393	37259	37320	37381	38501
25	28500	30000	30000	30000	30900
30	22997	24210	24249	24288	25016
35	18677	19663	19716	19769	20360
40	15253	16059	16119	16179	16662
45	12529	13191	13254	13317	13714
50	10340	10888	10950	11012	11341
55	8575	9030	9090	9150	9423
60	7145	7524	7581	7638	7866
65	5983	6300	6354	6408	6598
70	5032	5299	5349	5399	5559
75	4252	4478	4524	4570	4706
80	3606	3798	3840	3882	3997
85	3071	3235	3273	3311	3410
90	2624	2764	2799	2834	2918
95	2253	2373	2405	2437	2509
100	1940	2044	2073	2102	2164

Rmin1: Minimum Thermistor Resistance resulting from the Total Tolerance
 Rmin2: Minimum Thermistor Resistance resulting from the BETA-Tolerance
 Rnom : Typical Thermistor Resistance
 Rmax1: Maximum Thermistor Resistance resulting from the Total Tolerance
 Rmax2: Maximum Thermistor Resistance resulting from the BETA-Tolerance

3.3 OPTICAL CHARACTERISTICS

3.3.1 Parameter

TPS3x4					
Parameter	Limits			Units	Conditions
	Min	Typ	Max		
Field of View		60	70	degree	At 50% target signal
Optical Axis		0	±10	degree	

3.3.2 Sample Curve

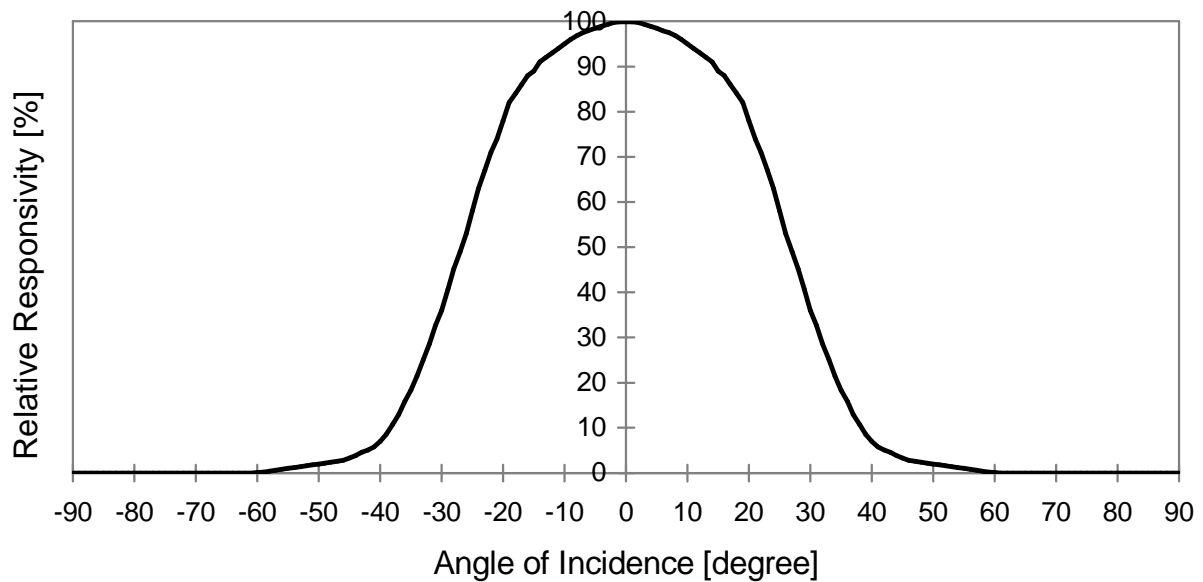

3.4 FILTER CHARACTERISTICS

3.4.1 Parameters

Standard Filter					
Parameter	Limits			Units	Conditions
	Min	Typ	Max		
Average Transmission	70			%	Wavelength Range from 7.5 μ m to 13.5 μ m
Average Transmission			1	%	Wavelength Range from Visual to 5 μ m
Cut On	5.2	5.5	5.8	μ m	At 25°C

3.4.2 Sample Curve

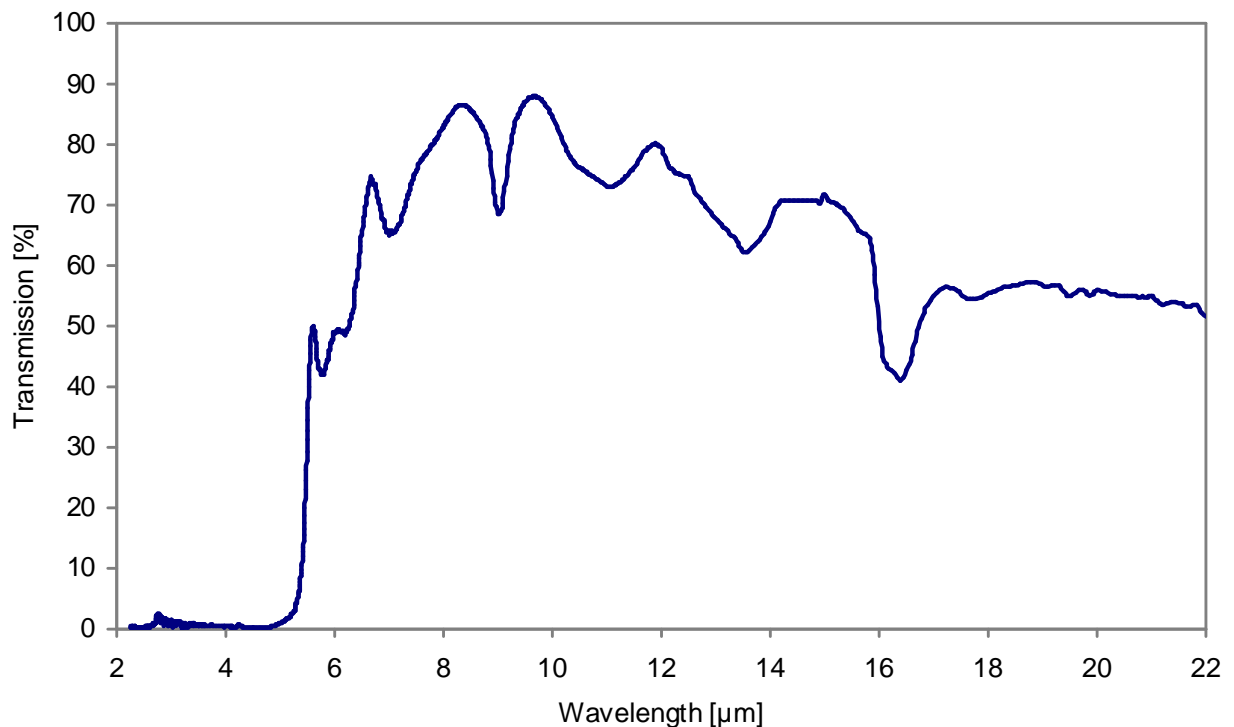



3.5 MECHANICAL DRAWING

4 QUALITY

The reproduction, transmission or use of this document or its contents is not permitted without express written permission of PerkinElmer. All rights, including patent, copyright or registration of a utility model or design are reserved.

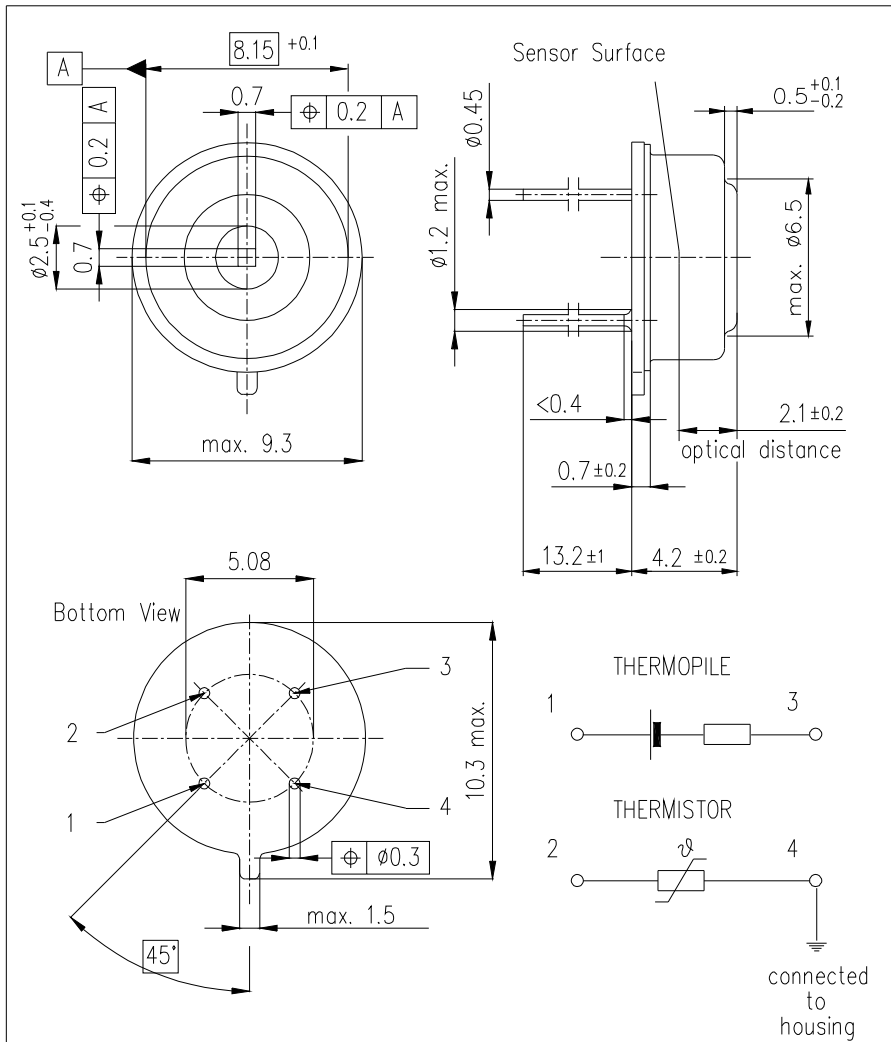
Weitergabe sowie Verwendigung dieser Unterlagen, Verwertung und Mitteilung ihres Inhalts nicht gestattet. Insbesondere sind die Rechte vorbehalten. Alle Rechte vorbehalten, insbesondere für den Fall der Patentierung oder GM-Eintragung.



Allgemeintoleranzen GENERAL TOLERANCES				±0.1	Werkstückkanten/EDGES OF WORKING-PARTS ACC. DIN 6784	Form- u. Lagetoleranzen GEOMETRICAL TOLERANCES
		Datum DATE	Name NAME		Werkstoff MATERIAL	 PerkinElmer [®] optoelectronics.
		Gez. DRAWN BY	25.11.98	Tkocz		
		Gepr. CHECKED BY				
		Maßstab SCALE	Benennung/TITLE			
			5:1	Dimensions and Connections TPS 334 (3+1)-Pin Thermopile with Thermistor		
Index NO.	Änderung REVISION	Datum DATE	Name NAME	Zeichnung Nr./DRAWING NO. 2/70985		
				Liefervorschrift/SPECIFICATION		
				Ersatz für/REPLACEMENT FOR		
				Ersetzt durch/REPLACED BY		

A4.dwg

4.1 QUALITY SYSTEM

HEIMANN is an ISO 9001 certified manufacturer. All materials are checked according to specifications and final goods meet the specified tests.

4.2 LOT ACCEPTANCE TEST

4.2.1 Test Conditions

Object emission	> 98%
Typical object temperature	226.8°C / 500K
Typical ambient temperature	25°C

4.2.2 Test Parameter

Parameter	Symbol	Limits			Units	Conditions
		Min	Typ	Max		
Resistance TPS	R _{TP}	50	75	100	kΩ	RT (room temperature)
Responsivity	S _V	20	35	50	V/W	Standard filter, 500K, 1Hz, RT
Resistance TH	R _{TH}	20	30	40	kΩ	RT
Parasitic resistance	R _{TP-TH}	0.5			GΩ	Tested between thermopile and thermistor

4.2.3 Test Level at the End Test

Lot conformance to specification of products delivered in volume production is checked by means of following tests (manufacturing) :

Test	Conditions	Level
Thermopile resistance	Acc. to the test parameters, tolerance check	100%
Thermopile Responsivity	Acc. to the test parameters, tolerance check	100%
Thermistor resistance	Acc. to the test parameters, functional check	100%
Parasitic resistance	Acc. to the test parameters, functional check	100%

4.2.4 Test Level at the Quality Test

Lot conformance to specification of products delivered in volume production is checked by means of following tests (quality) :

<i>Test</i>	<i>Conditions</i>	<i>Level</i>
Thermopile resistance	Acc. to the test parameters, tolerance check	AQL0.1
Thermistor resistance	Acc. to the test parameters, functional check	AQL0.1
Thermopile responsivity	Acc. to the test parameters, tolerance check	AQL0.1
Parasitic resistance	Acc. to the test parameters, functional check	AQL0.4

4.3 REFERENCED DOCUMENTS

The referenced documents form a part of this drawing. The revision level of these referenced documents unless defined shall be that which is in effect on the date of the purchase order.

4.4 LIABILITY POLICY

Changes or modifications at the product which haven't influence to the performance and/or quality of the device haven't to be announced to said customer in advance or approved by said customer. Customers are advised to consult with PerkinElmer Optoelectronics sales representatives before ordering. Customers considering the use of PerkinElmer Optoelectronics thermopile devices in special applications where failure or abnormal operation may directly affect human lives or cause physical injury or property damage, or where extremely high levels of reliability are demanded, are requested to consult with PerkinElmer Optoelectronics sales representatives before such use. The company will not be responsible for damage arising from such use without prior approval.

As any semiconductor device, thermopile sensors or modules have inherently a certain rate of failure. It is therefore necessary to protect against injury, damage or loss from such failures by incorporating safety design measures into the equipment.